

HCAL serial link architecture

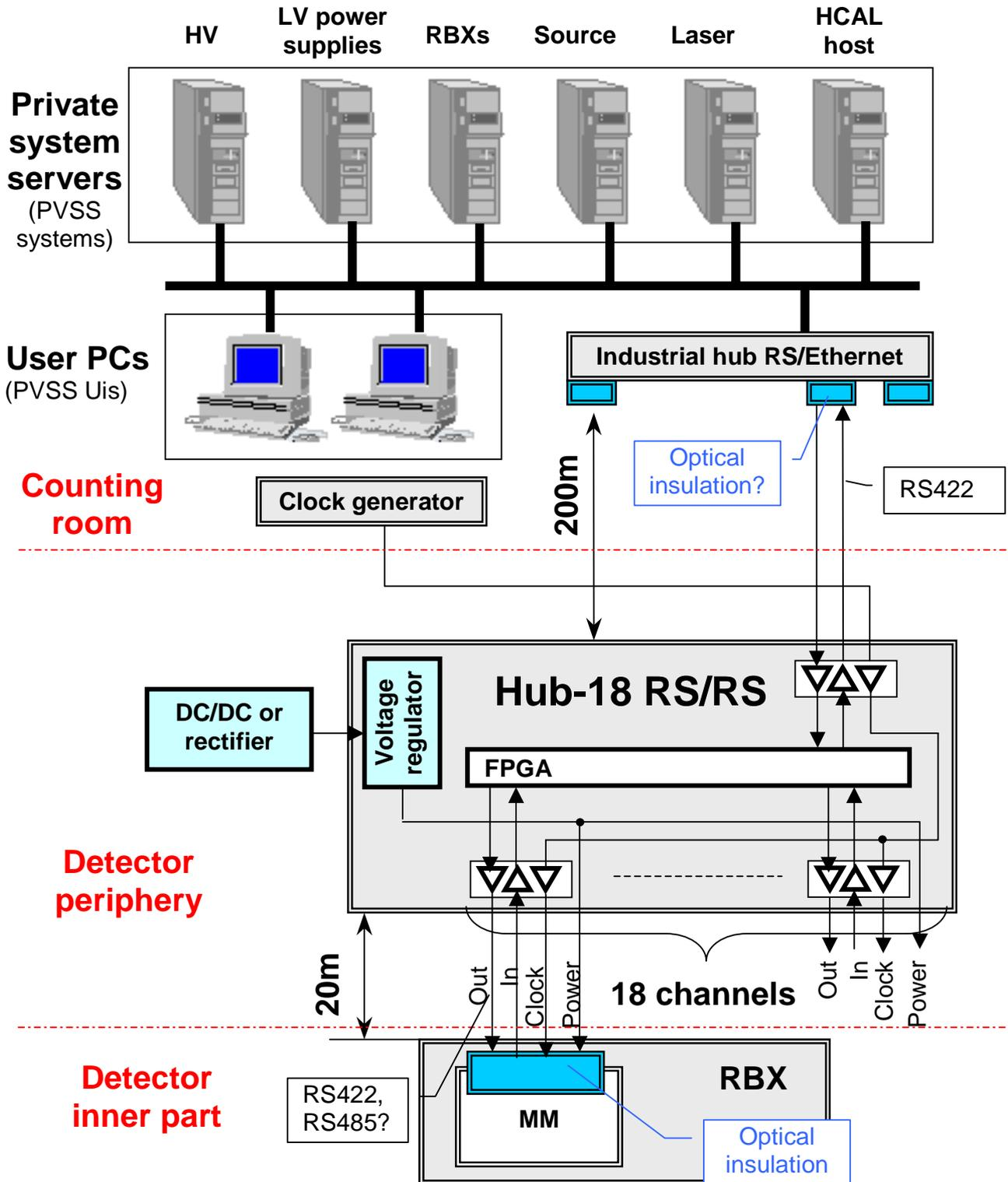

EMU on-board LV monitoring

EMU electronics scheme is taken from the report of T.Y.Ling at USCMS EMU Meeting Fermilab, October 5-6, 2000 (<http://cmssun1.ucr.edu:8080/~cms/oct01/oct01.html>) see http://www.physics.ohio-state.edu/~ling/elec/emu_elec_status_oct01.pdf

